

Ma

KEY STAGE  
3

TIER  
5–7

2002

# Mathematics test

## Paper 2

### Calculator allowed

Please read this page, but do not open your booklet until your teacher tells you to start. Write your name and the name of your school in the spaces below. If you have been given a pupil number, write that also.

First name \_\_\_\_\_

Last name \_\_\_\_\_

School \_\_\_\_\_

Pupil number

--	--	--	--	--	--

#### Remember

- The test is 1 hour long.
- You may use a calculator for any question in this test.
- You will need: pen, pencil, rubber, ruler, an angle measurer or protractor, a pair of compasses and a scientific or graphic calculator.
- Some formulae you might need are on page 3.
- This test starts with easier questions.
- Try to answer all the questions.
- Write all your answers and working on the test paper – do not use any rough paper.
- Check your work carefully.
- Ask your teacher if you are not sure what to do.

For marker's  
use only

Total marks	
Borderline check	

---

**BLANK PAGE**

## Instructions

### Answers



This means write down your answer or show your working and write down your answer.

### Calculators



You **may** use a calculator to answer any question in this test.

## Formulae

You might need to use these formulae

### Trapezium

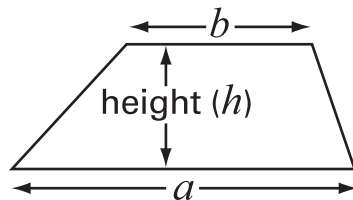

$$\text{Area} = \frac{1}{2}(a + b)h$$

### Prism

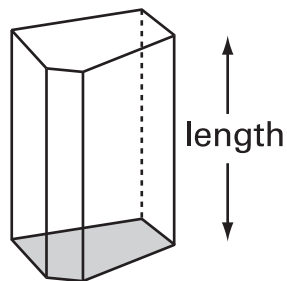

$$\text{Volume} = \text{area of cross-section} \times \text{length}$$

1. Some people use **yards** to measure length.

The diagram shows one way to change yards to metres.

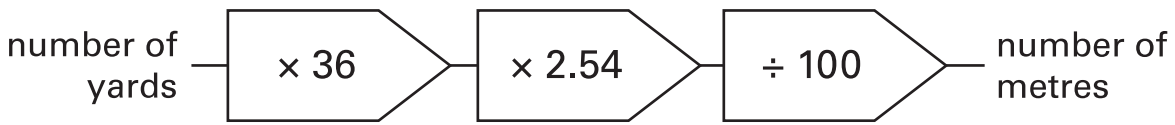

(a) Change **100 yards** to metres.



..... metres

1 mark

(b) Change **100 metres** to yards.

Show your working.



..... yards

.....  
2 marks

2. A scale measures in **grams** and in **ounces**.

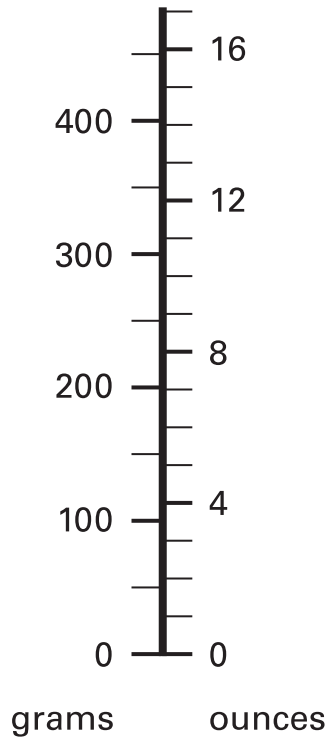

Use the scale to answer this question.

About how many ounces is **1 kilogram**?

Explain your answer.



..... ounces

.....

2 marks



3. A door has a security lock.

To open the door you must press the correct buttons.

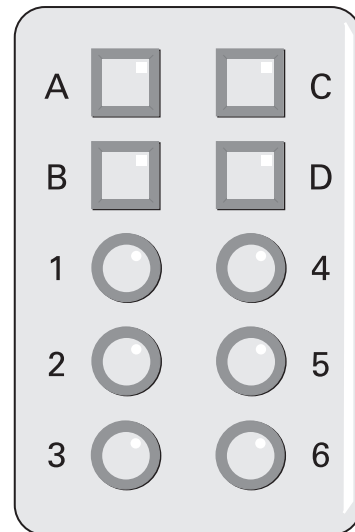

The code for the door is one letter followed by a single digit number.  
For example: B6

(a) How many **different** codes are there altogether?  
Show your working.



.....

.....  
2 marks

(b) I know that the correct code begins with D  
I press D, then I guess the single digit number.

What is the probability that I open the door?



1 mark

4. Screenwash is used to clean car windows.  
To use Screenwash you mix it with water.

Winter mixture
Mix <b>1</b> part Screenwash with <b>4</b> parts water.

Summer mixture
Mix <b>1</b> part Screenwash with <b>9</b> parts water.

- (a) In **winter**, how much water should I mix with **150 ml of Screenwash**?



..... ml

1 mark

- (b) In **summer**, how much Screenwash should I mix with **450 ml of water**?



..... ml

1 mark

- (c) Is this statement correct?

**25% of winter mixture is Screenwash.**

Tick (✓) Yes or No.



Yes

No

Explain your answer.



1 mark



5. (a) I have a paper circle.

Then I cut a sector from the circle. It makes this net.

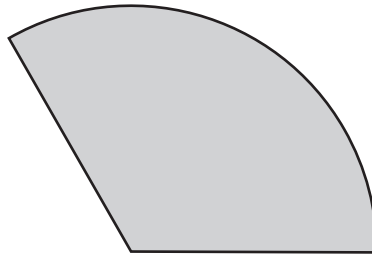

Which 3-D shape below could I make with my net?

Tick (✓) your answer.

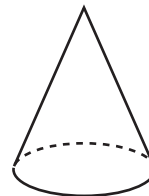
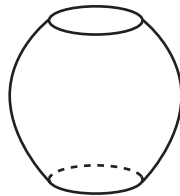
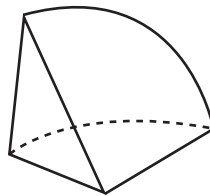
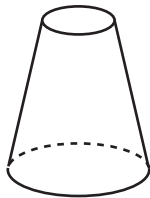

1 mark



(b) Here is a sketch of my net.

Not drawn accurately

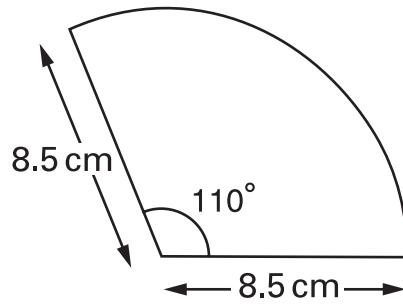

Make an **accurate drawing** of my net.



.....

.....

3 marks



6. A teacher has a large pile of cards.  
An expression for the **total** number of cards is  $6n + 8$

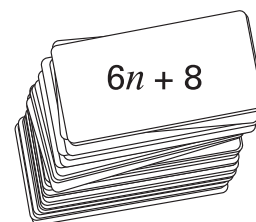

- (a) The teacher puts the cards in two piles.  
The number of cards in the first pile is  $2n + 3$

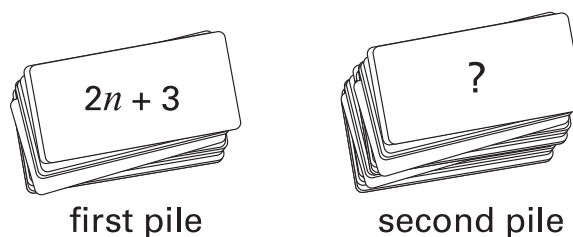

Write an expression to show the number of cards in the second pile.



1 mark

- (b) The teacher puts all the cards together.  
Then he uses them to make **two equal piles**.

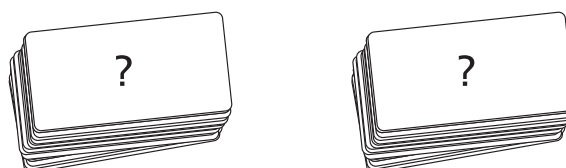
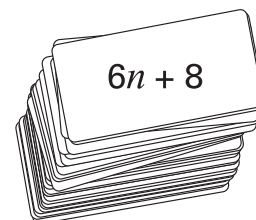

Write an expression to show the number of cards in one of the piles.



1 mark

(c) The teacher puts all the cards together again, then he uses them to make two piles.

There are **23** cards in the first pile.

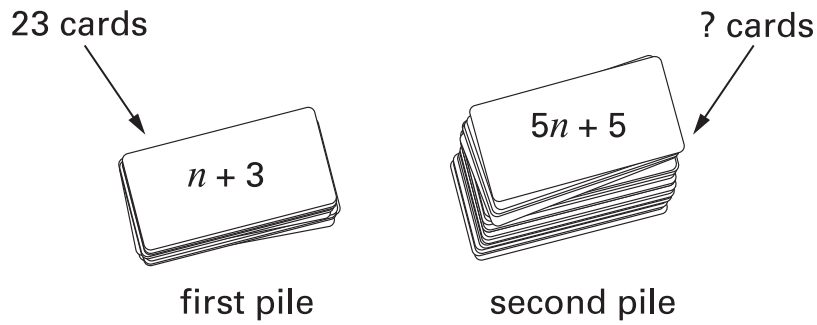

How many cards are in the second pile?

Show your working.



.....  
.....  
.....

2 marks



7. Hannah went on a cycling holiday.  
The table shows how far she cycled each day.

Monday	Tuesday	Wednesday	Thursday
32.3 km	38.7 km	43.5 km	45.1 km

Hannah says:

'On average, I cycled **over 40 km** a day'.

Show that Hannah is wrong.



.....

2 marks

8. The drawing shows 2 cuboids that have the **same volume**.

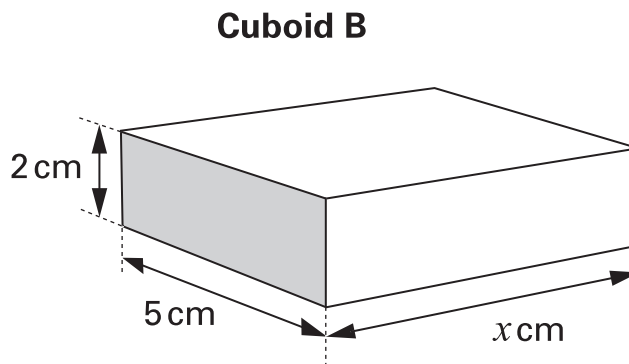
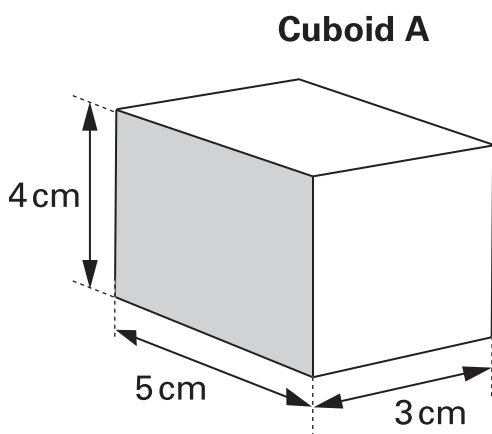

Not drawn accurately

(a) What is the volume of cuboid A?  
Remember to state your units.



1 mark

.....

1 mark

(b) Work out the value of the length marked  $x$



..... cm

1 mark



9. The diagram shows a rectangle.

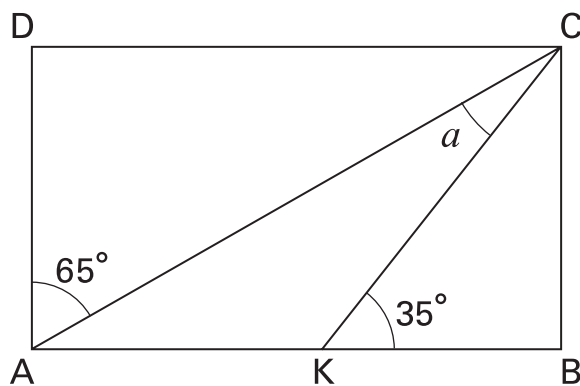

Not drawn accurately

Work out the size of angle  $a$

You **must** show your working.



$$a = \dots\dots\dots^\circ$$

.....

.....

3 marks

10. A company sells and processes films of two different sizes.  
The tables show how much the company charges.

Film size: <b>24</b> photos	
Cost to <b>buy</b> each film	£ 2.15
Postage	free
Cost to <b>print</b> each film	£ 0.99
<b>Postage</b> for each film	60p

Film size: <b>36</b> photos	
Cost to <b>buy</b> each film	£ 2.65
Postage	free
Cost to <b>print</b> each film	£ 2.89
<b>Postage</b> for each film	60p

I want to take **360** photos.

I need to buy the film, pay for the film to be printed,  
and pay for the postage.

Is it cheaper to use all films of size 24 photos, or all films of size 36 photos?  
How much cheaper is it? Show your working.



Use film size: ..... photos

How much cheaper

£

4 marks

11. Look at the equations.

$$3a + 6b = 24$$

$$2c - d = 3$$

(a) Use the equations to work out the value of the expressions below.  
The first one is done for you.

$8c - 4d = \dots 12$
$a + 2b = \dots$
$d - 2c = \dots$

1 mark

1 mark

(b) Use one or both of the equations to write an expression that has a value of **21**

$\dots = 21$
--------------

1 mark



12. The shapes in this question are drawn on square grids.

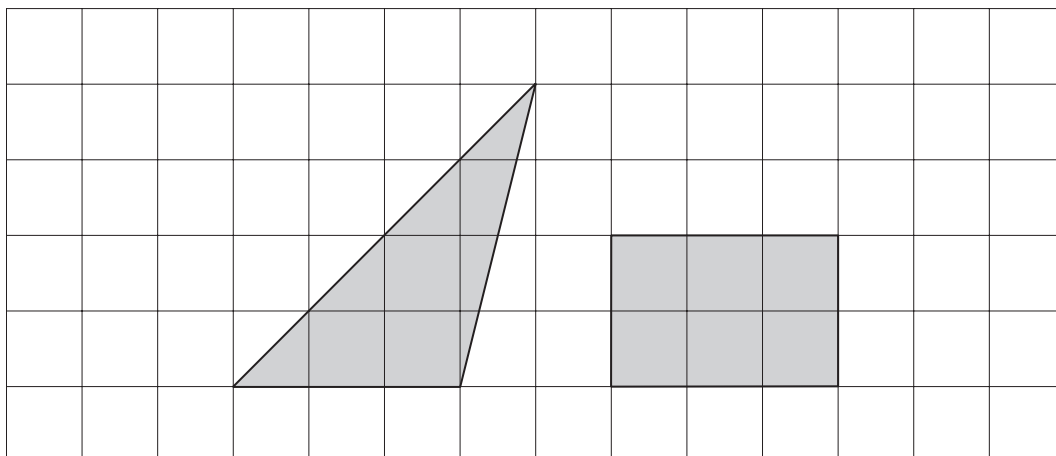

- (a) Show that the triangle and the rectangle have the **same area**.



1 mark

- (b) On the grid below, draw a **parallelogram** that has the same area as the triangle. It must **not** have any right angles.

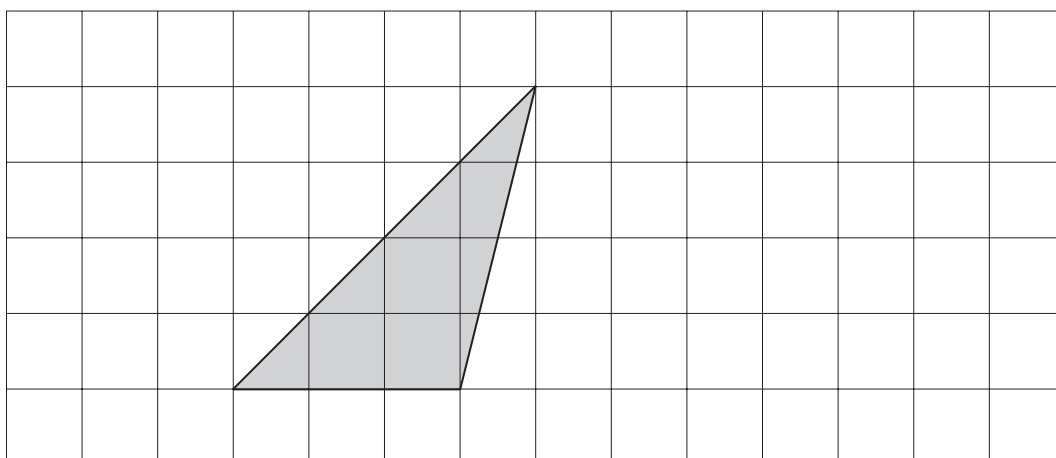

1 mark



13. A newspaper wrote an article about public libraries in England and Wales. It published this diagram.

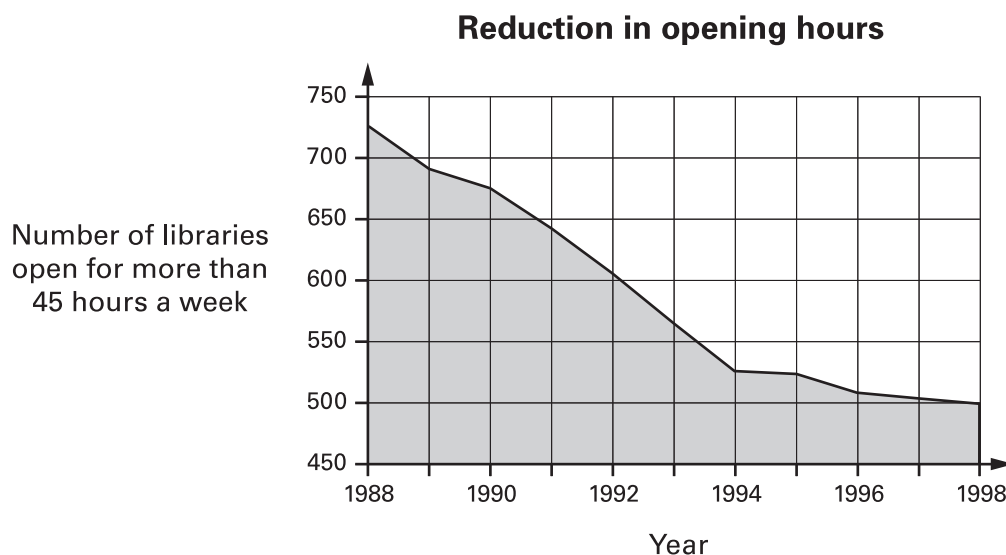

Use the diagram to decide whether each statement below is true or false, or whether you cannot be certain.

- (a) The number of libraries open for more than 45 hours per week **fell by more than half** from 1988 to 1998.



True

False

Cannot be certain

Explain your answer.



1 mark

- (b) **In 2004** there will be **about 450 libraries** open in England and Wales for more than 45 hours a week.



True

False

Cannot be certain

Explain your answer.



1 mark

14. (a) Each point on the straight line  $x + y = 12$  has an  $x$  coordinate and a  $y$  coordinate that **add together** to make **12**  
Draw the straight line  $x + y = 12$

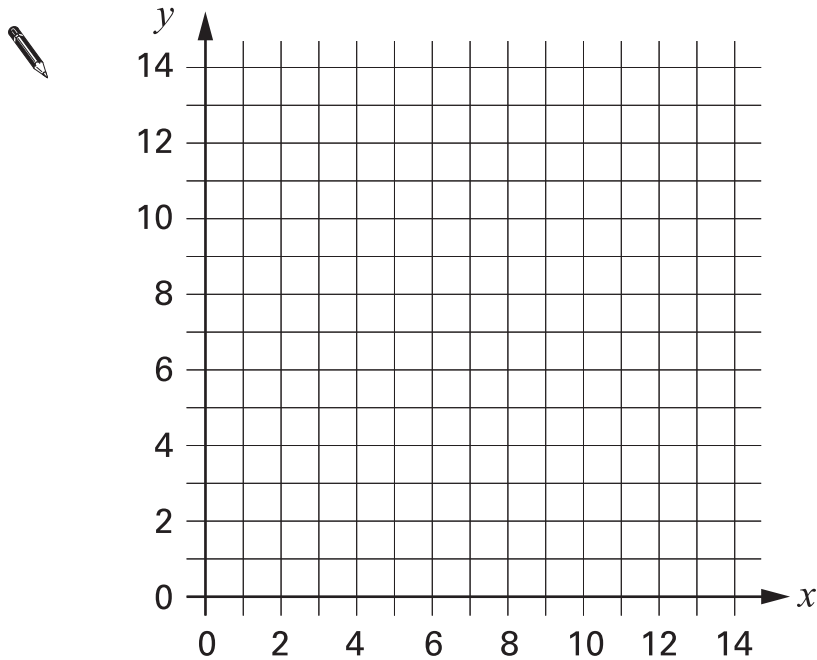

1 mark

- (b) Plot on the grid below at least 6 points whose  $x$  coordinate and  $y$  coordinate **multiply together** to make 12  
Then draw the part of the curve  $xy = 12$  that you would see on the grid below.

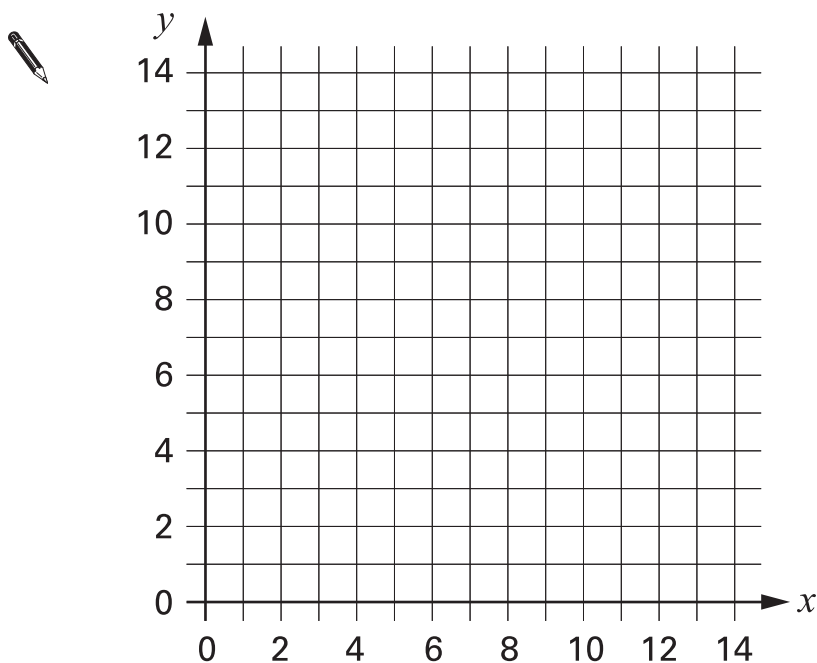

.....

2 marks

15. I went for a walk.

The distance–time graph shows information about my walk.

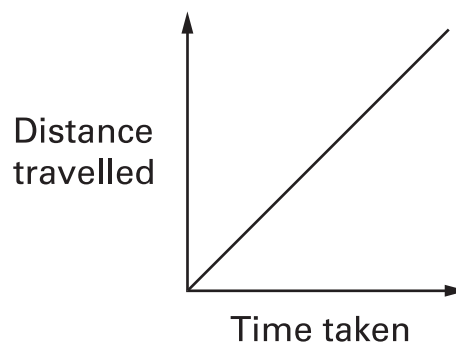

Tick (✓) the statement below that describes my walk.



I was walking faster and faster.

I was walking slower and slower.

I was walking north-east.

I was walking at a steady speed.

I was walking uphill.

1 mark

16. (a) From 5th May 2000 to 5th May 2001 a swimming club had the same members.

Complete the table to show information about the ages of these members.

Ages of members	
Mean (5th May 2000)	24 years 3 months
Range (5th May 2000)	4 years 8 months
Mean (5th May 2001)	
Range (5th May 2001)	



1 mark

(b) The table below shows information about members of a different club.

Ages of members	
Mean	17 years 5 months
Range	2 years 0 months

A new member, aged **18 years 5 months**, is going to join the club.

What will happen to the **mean** age of the members?

Tick (✓) the correct statement below.



It will increase by more than 1 year.

It will increase by exactly 1 year.

It will increase by less than 1 year.

It will stay the same.

It is not possible to tell.

1 mark

What will happen to the **range** of ages of the members?



It will increase by more than 1 year.

It will increase by exactly 1 year.

It will increase by less than 1 year.

It will stay the same.

It is not possible to tell.

1 mark

17. (a) The grid shows an arrow.

On the grid, draw an **enlargement** of **scale factor 2** of the arrow.

Use **point C** as the centre of enlargement.

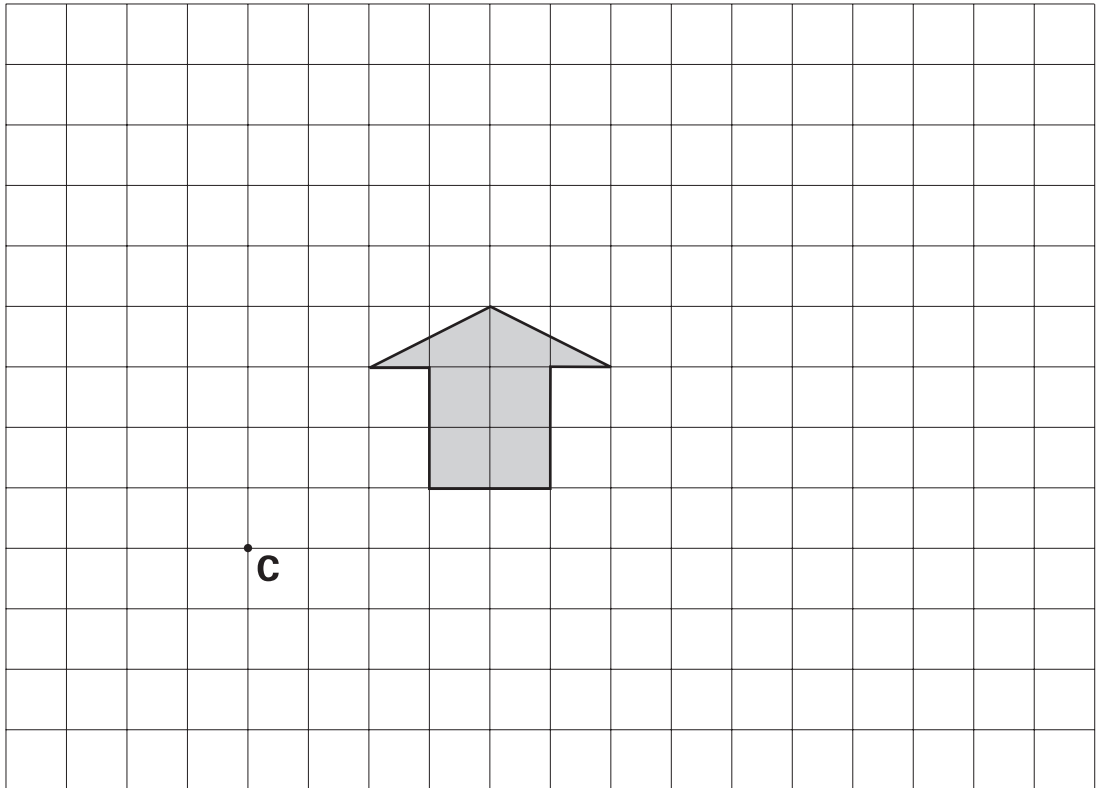

.....  
2 marks

(b) The sketch below shows two arrows.

The bigger arrow is an **enlargement** of **scale factor 1.5** of the smaller arrow.

Write down the **three** missing values.

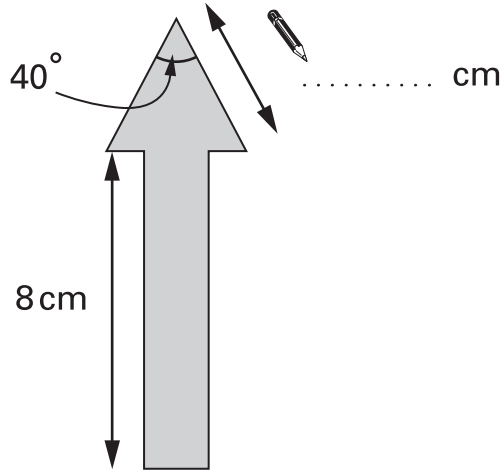

1 mark

Not drawn accurately

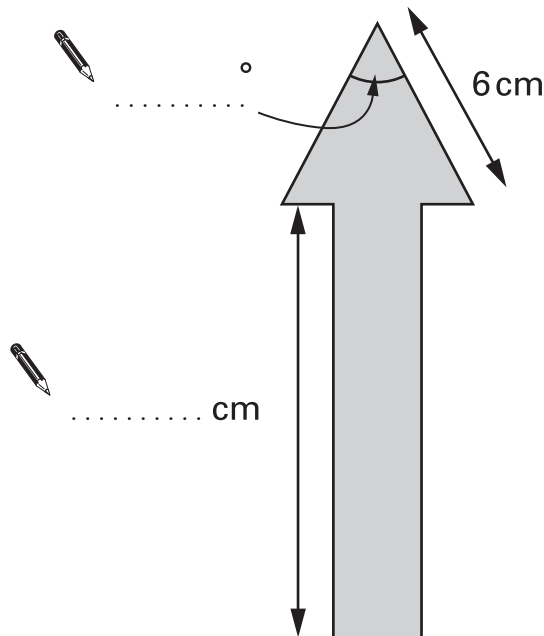

1 mark

1 mark



18. A box contains cards with one question on each card.  
 There are 4 categories of questions.  
 Each category has some easy and some difficult questions.

The table shows the probability of selecting a card at random from the box.

Category	Easy	Difficult
Music	0.2	0.15
Sport	0.2	0.1
History	0.1	0.05
Nature	0.15	0.05

- (a) I am going to take one card at random from the box.  
 What is the probability that it will be

a **history** question?



.....

1 mark

an **easy** question?



.....

1 mark

- (b) There are **40** cards in the box.  
 How many of these are **music** questions?



.....

1 mark



19. The diagram shows a square and a circle.  
The circle touches the edges of the square.

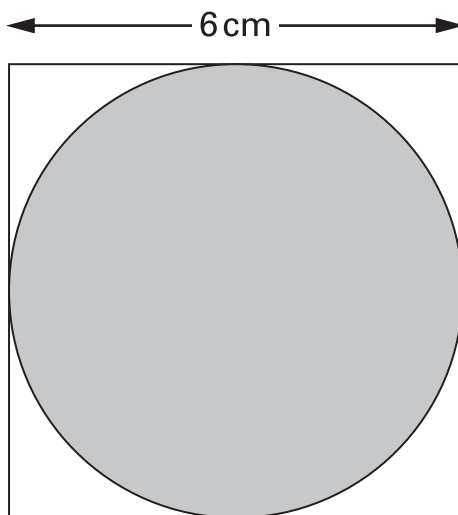

What **percentage** of the diagram is shaded?

Show your working.



.....  
 .....  
 ..... %  
 3 marks



20. The percentage charts show information about the wing length of adult blackbirds, measured to the nearest millimetre.

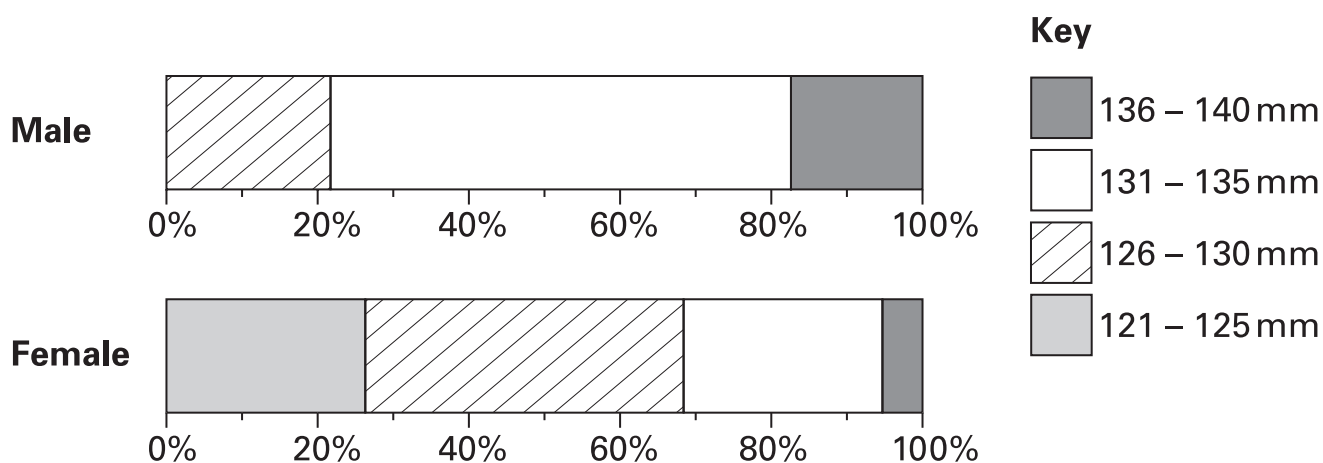

Use the data to decide whether these statements are true or false, or whether there is not enough information to tell.

The smallest male's wing length is larger than the smallest female's wing length.



True

False

Not enough information

Explain your answer.



1 mark

The biggest male's wing length is larger than the biggest female's wing length.



True

False

Not enough information

Explain your answer.



1 mark

21. (a) One calculation below gives the answer to the question

**What is 70 increased by 9%?**

Tick (✓) the correct one.

$$70 \times 0.9$$

$$70 \times 1.9$$

$$70 \times 0.09$$

$$70 \times 1.09$$

1 mark

Choose one of the other calculations.

Write a question **about percentages** that this calculation represents.



calculation chosen: .....

question it represents: .....

1 mark

Now do the same for one of the remaining two calculations.



calculation chosen: .....

question it represents: .....

1 mark

(b) Fill in the missing decimal number.



To decrease by 14%, multiply by .....

1 mark



**END OF TEST**